

FEIDER
MACHINES

Original Instructions
VACUUM CLEANER – WATER AND DUST
FHAEP1430L



Read instructions before use the tool

BUILDER SAS
ZI du Casque, 32 rue Aristide Bergès - 31270 Cugnaux - France

CE

1

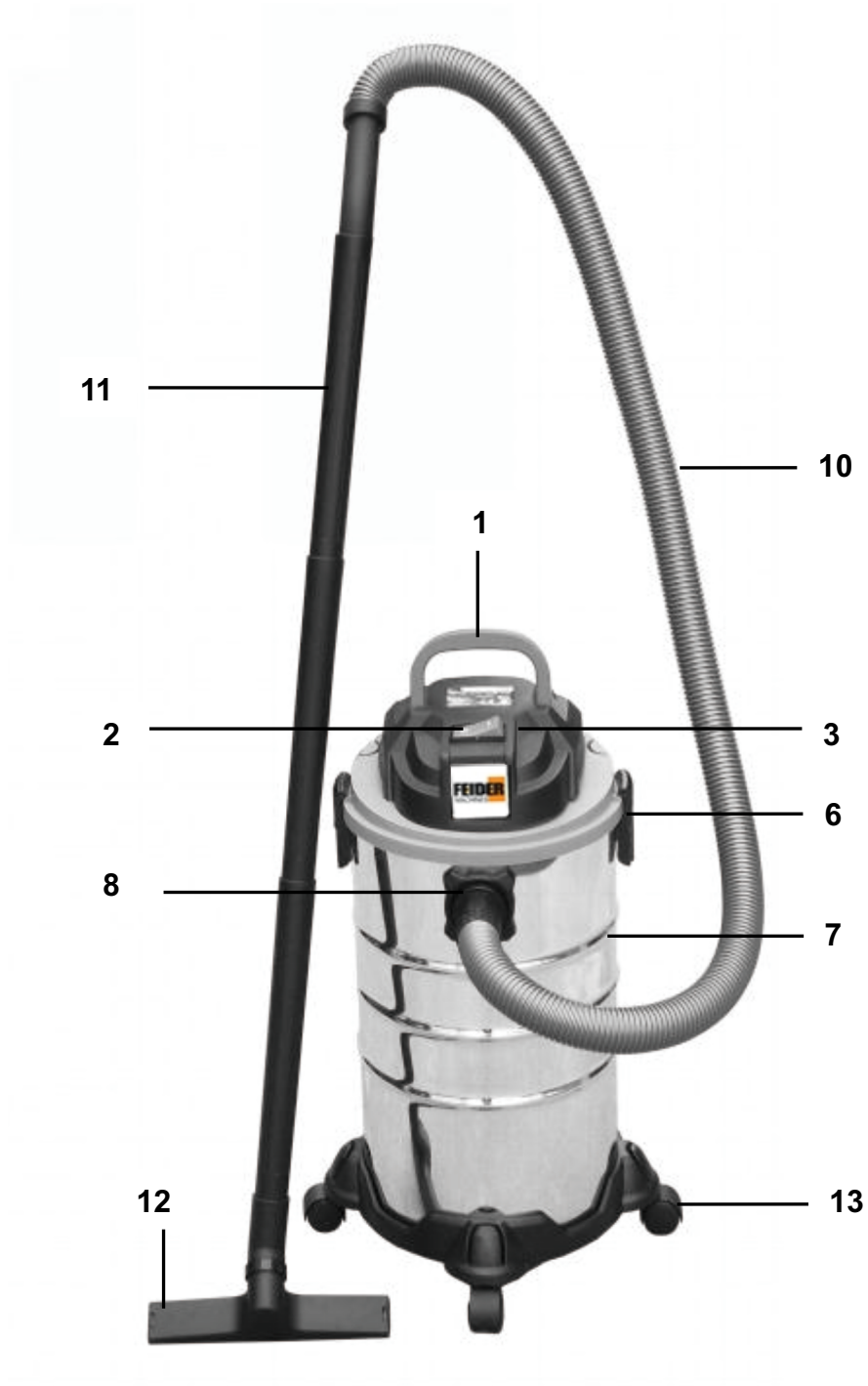

2

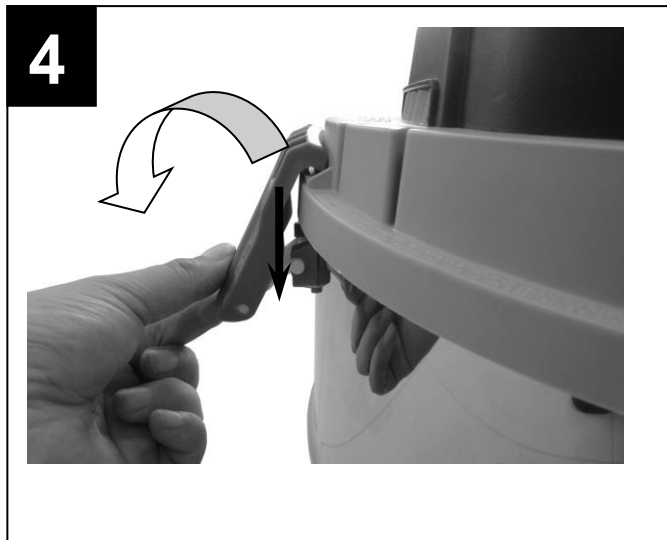
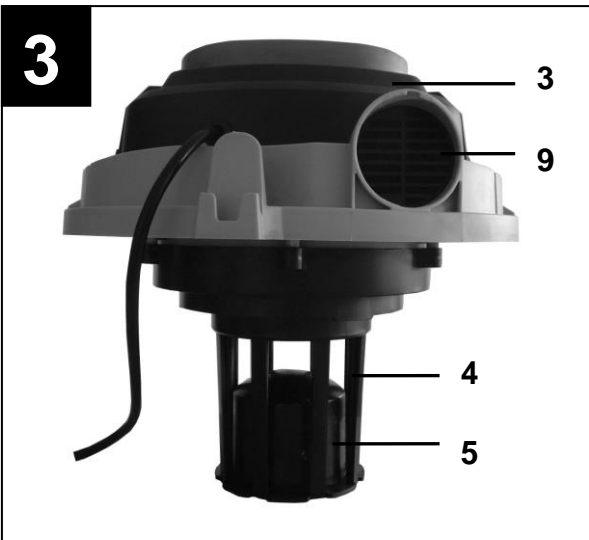
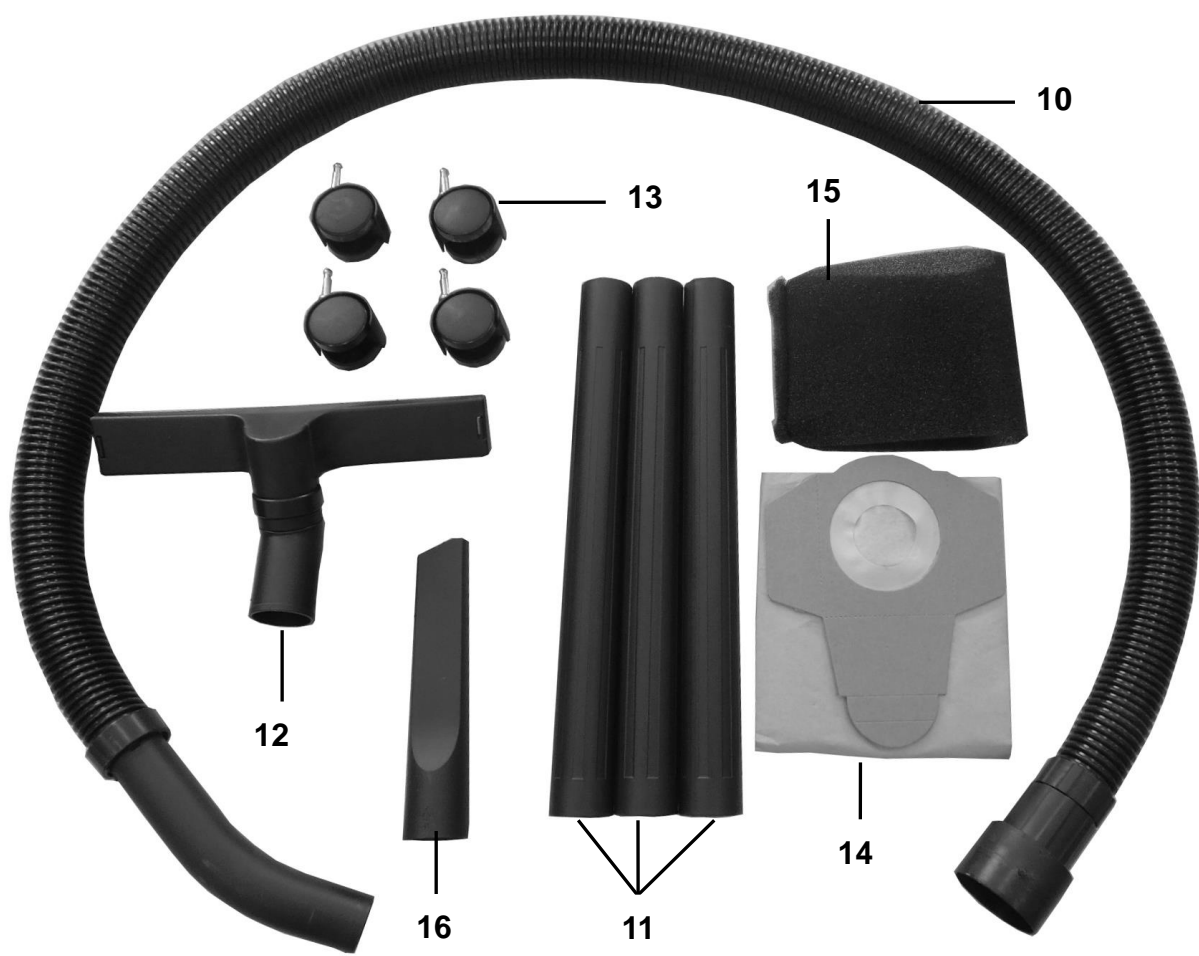

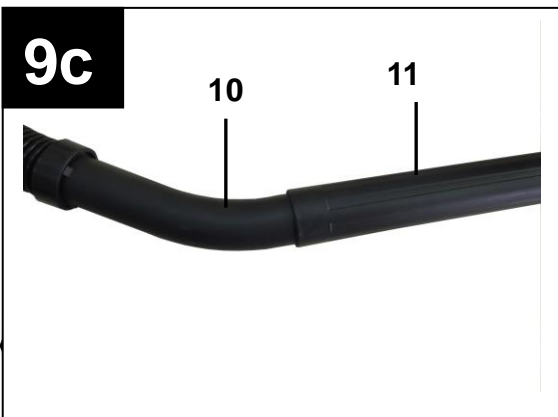
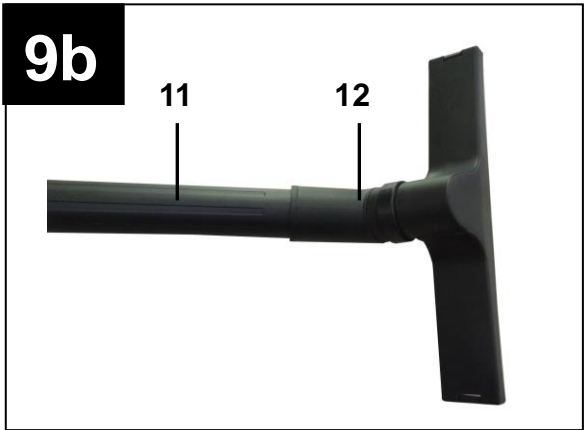
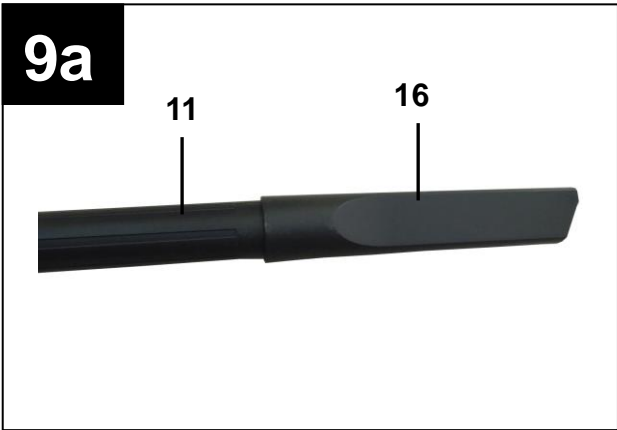
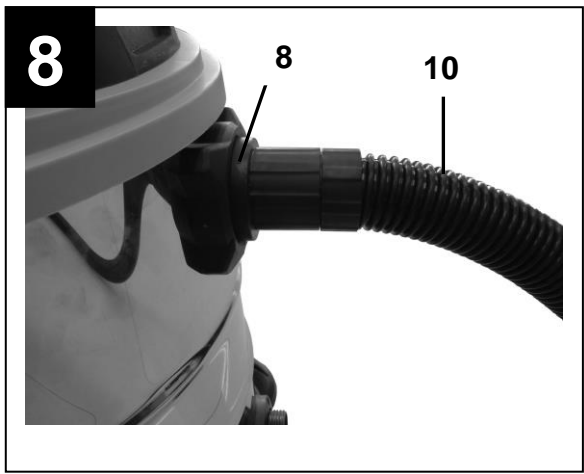
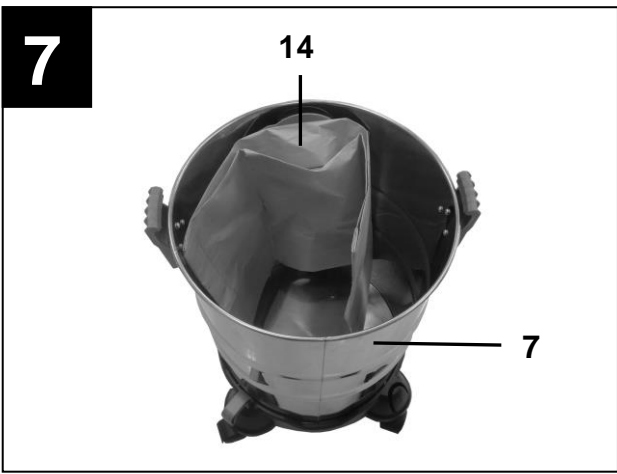
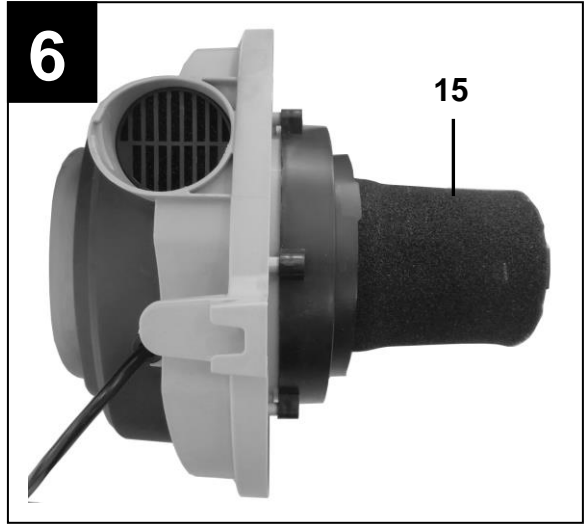
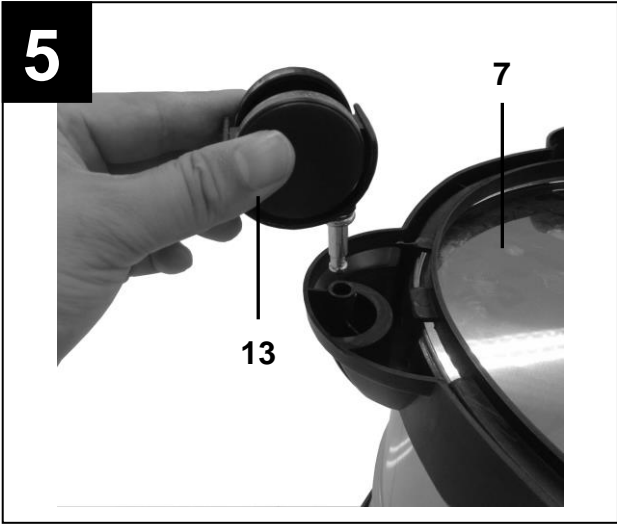

IMPORTANT!

When using equipment, a few safety precautions must be observed to avoid injuries and damage. Please read the complete operating manual with due care. Keep this manual in a safe place, so that the information is available at all times. If you give the equipment to any other person, give them these operating instructions as well.

We accept no liability for damage or accidents which arise due to non-observance of these instructions and the safety information.

1. Safety information

- **Important: Read the operating instructions before assembling and using the appliance for the first time.**
- **Check that the mains voltage is the same as the mains voltage specified on the rating plate.**
- **Only connect the appliance to a properly fitted 220-240 V~ 50 /60Hz shock-proof socket.**
- **Pull out the power plug in the following circumstances: Whenever the appliance is not in use, before opening the appliance and before all cleaning and maintenance work.**

- **Never clean the appliance with solvents.**
- **Never pull the plug out of the socket by pulling the cable.**
- **Never leave the appliance unattended when operational.**
- **Keep away from children.**
- **Take care to ensure that the power cable does not get damaged by being run over, crushed, pulled or suchlike.**
- **Do not use the machine if the power cable is in a less than perfect condition.**
- **Never vacuum the following: Burning matches, smoldering ash and cigarette butts, combustible, caustic, inflammable or explosive substances, vapor or liquids.**
- **This appliance is not suitable for vacuuming dust which can be harmful to health.**
- **Store the appliance in a dry indoor location.**
- **Never use the appliance if it is damaged.**
- **Only allow the appliance to be serviced by an authorized after sales service outlet.**
- **Only use the appliance to carry out work for which has**

been designed.

- **Take extra care when cleaning steps.**
- **Use only genuine accessories and spare parts.**
- **This appliance can be used by children aged from 8 years and above and persons with reduced physical, sensory or mental capabilities or lack of experience and knowledge if they have been given supervision or instruction concerning use of the appliance in a safe way and understand the hazards involved. Children shall not play with the appliance. Cleaning and user maintenance shall not be made by children without supervision.**
- **If the supply cord is damaged, it must be replaced by the manufacturer, its service agent or similarly qualified persons in order to avoid a hazard.**
- **The plug must be removed from the socket-outlet before cleaning or maintaining the appliance.**

2. Layout and items supplied (Fig. 1-3)

1. Handle
2. ON/OFF
3. Head
4. Filter cage
5. Safety float valve
6. Locking hook
7. Tank
8. Suction hose connection
9. Blow connector
10. Flexible suction hose
11. 3-part suction tube
12. Combination nozzle
13. Wheels
14. Dirt bag
15. Foam filter
16. Crevice nozzle
17. Hook for cable store

3. Intended use

The wet and dry vacuum cleaner is designed for wet and dry vacuuming using the appropriate filter. The appliance is not suitable for the vacuuming of combustible, explosive or harmful substances.

The machine is to be used only for its prescribed purpose. Any other use is deemed to be a case of misuse. The user / operator and not the manufacturer will be liable for any damage or injuries of any kind caused as a result of this.

Please note that our equipment has not been designed for use in commercial, trade or industrial applications. Our warranty will be voided if the machine is used in commercial, trade or industrial businesses or for equivalent purposes.

4. Technical data

Mains voltage: 220-240V~ 50/60 Hz

Model	Power input	Tank volume
FHAEP1430L	1400W	30 L

5. Before starting



Important!

- Before you connect the appliance to the mains supply make sure that the data on the rating plate are identical to the mains data.
- The appliance may only be connected to a shockproof socket.

5.1 Appliance assembly

Fitting the appliance head (Fig. 4)

The appliance head (3) is fastened to the container (7) by the locking hook (6). To remove the appliance head (3), open the locking hook (6) and remove the appliance head (3). When fitting the appliance head (3), make sure that the locking hook (6) locks into place correctly.

Assembling the wheels (Fig. 5)

Fit the wheels (13) in accordance with fig. 5.

Mounting the hook for the cable store (Fig. 10)

Press the hook for the cable store (17) into the mount. After use, the power cable can be wound up onto the hook (17) and the head (3).

5.2 Fitting the filter



Important!

Never use the wet and dry vacuum cleaner without a filter.
Check that the filter is securely fitted at all times.

Fitting the foam filter (Fig. 6)

For wet vacuuming, slip the supplied foam filter (15) over the filter cage (Fig. 3/4).

Assembling the dirt bag (Fig. 7)

For dry vacuuming, slip the dirt bag (14) over the vacuuming hole. The dirt bag (14) is suitable for dry vacuuming only. The dirt bag makes it easier to dispose of the sucked-in dust.

5.3 Fitting the suction hose (Fig. 3, 8, 9)

Connect the suction hose (10) to the corresponding connector on the wet and dry vacuum cleaner, depending on the application required.

Vacuuming

Connect the suction hose (10) to the suction hose connector (8).

Blowing

Connect the suction hose (10) to the blow connector (9).

The 3-part suction tube (11) can be attached to the suction hose (10) to extend it.

5.4 Suction nozzles

Combination nozzle (12)

The combination nozzle (12) with attachments is for vacuuming solids and liquids over medium to large areas. The crevice nozzle (16) is specially designed for cleaning crevices and edges.

6. Operation



Important!

Switch off the equipment if liquid or foam is emitted with the exhaust air when wet vacuum cleaning.

6.1 On/Off switch (Fig. 1)

Switch position 0: Off

Switch position I: On

6.2 Dry vacuuming

Use the dirt bag (14) for dry vacuuming (see point 5.2).

Always ensure that the filters are perfectly secure.

6.3 Wet vacuuming

For wet-vacuuming, use the foam filter (15) (see point 5.2).

Check that the filter is securely fitted at all times.



Important!

When wet vacuuming, the floating safety switch (5) closes when the maximum tank level is reached. In doing so, the suction noise of the equipment will change and become louder. You must then switch off the equipment and empty the tank.



Important!

The wet and dry vacuum cleaner is not suitable for the vacuuming of combustible liquids. For wet vacuuming, use only the supplied foam filter.

6.4 Blowing

Connect the suction hose (10) to the blow connector (9) on the wet and dry vacuum cleaner.

7. Cleaning, maintenance and ordering of spare parts



Important!

Always pull out the mains power plug before starting any cleaning work.

7.1 Cleaning

- Keep all safety devices, air vents and the motor housing free of dirt and dust as far as

possible.

- We recommend that you clean the appliance immediately after you use it.

7.2 Cleaning the appliance head (3)

Clean the appliance regularly with a damp cloth and some soft soap. Do not use cleaning agents or solvents; these may be aggressive to the plastic parts in the appliance.

7.3 Cleaning the container (7)

The container can be cleaned with a damp cloth and some soft soap or under running water, depending on the amount of dirt.

7.4 Cleaning the foam filter (15)

Clean the foam filter (15) with a little soft soap under running water and allow it to air-dry.

7.5 Maintenance

At regular intervals and before each use, check that the filters in the wet and dry vacuum cleaner are securely fitted.

7.6 Ordering replacement parts

Please quote the following data when ordering replacement parts:

- Type of machine
- Replacement part number of the part required

8. Disposal and recycling



The unit is supplied in packaging to prevent its being damaged in transit. This packaging is raw material and can therefore be reused or can be returned to the raw material system. The unit and its accessories are made of various types of material, such as metal and plastic. Defective components must be disposed of as special waste. Ask your dealer or your local council.

9. Symbols used on label



Read instruction manual



Class II protection

10. WARRANTY



WARRANTY

The manufacturer guarantees the product against defects in material and workmanship for a period of 2 years from the date of the original purchase. The warranty only applies if the product is for household use. The warranty does not cover breakdowns due to normal wear and tear.

The manufacturer agrees to replace parts identified as defective by the designated distributor. The manufacturer does not accept responsibility for the replacement of the machine, in whole or in part, and/or ensuing damage.

The warranty does not cover breakdowns due to:

- insufficient maintenance.
- abnormal assembly, adjustment or operations of the product.
- parts subject to normal wear and tear.

The warranty does not extend to:

- shipping and packaging costs.
- using the tool for a purpose other than that for which it was designed.
- the use and maintenance of the machine done in a manner not described in the user manual.

Due to our policy of continuous product improvement, we reserve the right to alter or change specifications without notice. Consequently, the product may be different from the information contained therein, but a modification will be undertaken without notice if it is recognized as an improvement of the preceding characteristic.

READ THE MANUAL CAREFULLY BEFORE USING THE MACHINE.

When ordering spare parts, please indicate the part number or code, you can find this in the spare parts list in this manual. Keep the purchase receipt; without it, the warranty is invalid. To help you with your product, we invite you to contact us by phone or via our website:

- **+33 (0)9.70.75.30.30**
- **<https://services.swap-europe.com/contact>**

You must create a "ticket" via the web platform.

- Register or create your account.
- Indicate the reference of the tool.
- Choose the subject of your request.
- Describe your problem.
- Attach these files: invoice or sales receipt, photo of the identification plate (serial number), photo of the part you need (for example: pins on the transformer plug which are broken).



11. PRODUCT FAILURE

WHAT TO DO IF MY MACHINE BREAKS DOWN?

If you bought your product in a store:

- a) Empty the fuel tank.
- b) Make sure that your machine is complete with all accessories supplied, and clean! If this is not the case, the repairer will refuse the machine.

Go to the store with the complete machine and with the receipt or invoice.

If you bought your product on a website:

- a) Empty the fuel tank.
- b) Make sure that your machine is complete with all accessories supplied, and clean! If this is not the case, the repairer will refuse the machine.
- c) Create a SWAP-Europe service ticket on the site: <https://services.swap-europe.com> When making the request on SWAP-Europe, you must attach the invoice and the photo of the nameplate (serial number).
- d) Contact the repair station to make sure it is available before dropping off the machine.

Go to the repair station with the complete machine packed, accompanied by the purchase invoice and the station support sheet downloadable after the service request is completed on the SWAP-Europe site

For machines with engine failure from manufacturers BRIGGS & STRATTON, HONDA and RATO, please refer to the following instructions.

Repairs will be done by approved engine manufacturers of these manufacturers, see their site:

- <http://www.briggsandstratton.com/eu/fr>
- <http://www.honda-engines-eu.com/fr/service-network-page;jsessionid=5EE8456CF39CD572AA2AEEDFD290CDAE>
- <https://www.rato-europe.com/it/service-network>

Please keep your original packaging to allow for after-sales service returns or pack your machine with a similar cardboard box of the same dimensions.

For any question concerning our after-sales service you can make a request on our website <https://services.swap-europe.com>

Our hotline remains available at +33 (9) 70 75 30 30.



12. WARRANTY EXCLUSIONS

THE WARRANTY DOES NOT COVER:

- Start-up and setting up of the product.
- Damage resulting from normal wear and tear of the product.
- Damage resulting from improper use of the product.
- Damage resulting from assembly or start-up not in accordance with the user manual.
- Breakdowns related to carburetion beyond 90 days and fouling of carburetors.
- Periodic and standard maintenance events.
- Actions of modification and dismantling that directly void the warranty.
- Products whose original authentication marking (brand, serial number) has been degraded, altered or withdrawn.
- Replacement of consumables.
- The use of non-original parts.
- Breakage of parts following impacts or projections.
- Accessories breakdowns.
- Defects and their consequences linked to any external cause.
- Loss of components and loss due to insufficient screwing.
- Cutting components and any damage related to the loosening of parts.
- Overload or overheating.
- Poor power supply quality: faulty voltage, voltage error, etc.
- Damages resulting from the deprivation of enjoyment of the product during the time necessary for repairs and more generally the costs related to the immobilization of the product.
- The costs of a second opinion established by a third party following an estimate by a SWAP-Europe repair station
- The use of a product which would show a defect or a breakage which was not the subject of an immediate report and/or repair with the services of SWAP-Europe.
- Deterioration linked to transport and storage*.
- Launchers beyond 90 days.
- Oil, petrol, grease.
- Damages related to the use of non-compliant fuels or lubricants.

* In accordance with transport legislation, damage related to transport must be declared to carriers within 48 hours maximum after observation by registered letter with acknowledgement of receipt.

This document is a supplement to your notice, a non-exhaustive list.

Attention: all orders must be checked in the presence of the delivery person. In case of refusal by the delivery person, it you must simply refuse the delivery and notify your refusal.

Reminder: the reserves do not exclude the notification by registered letter with acknowledgement within 72 hours.

Information:

Thermal devices must be wintered each season (service available on the SWAP-Europe site). Batteries must be charged before being stored.